

The most complete range for your end-of-line

<b>Case erectors</b>					
	BEM 100	BEM 200	BEM 200xs	BATEC	BEM XL
<b>Packing solutions</b>					
	ZENIT	SWING	Bizzy	Collaborative robot	Robotic solutions
<b>Case sealers</b>					
	CS15	CS25	CS35	CS45	
<b>Palletizers</b>					
	4AXIS	Cobot	Compact palletizing cells	Palletizing robot	
<b>Pallet wrappers</b>					
	LINE	SPIN	COVER		
<b>Semi-automatic pallet wrappers</b>					
	Single+ 2.0 FM	Single+ 2.0	Single+ 2.0 TP	SENIOR A 2.0	Fenix+
					
	Ronda 900+	Rotex 700	Rotex 800		

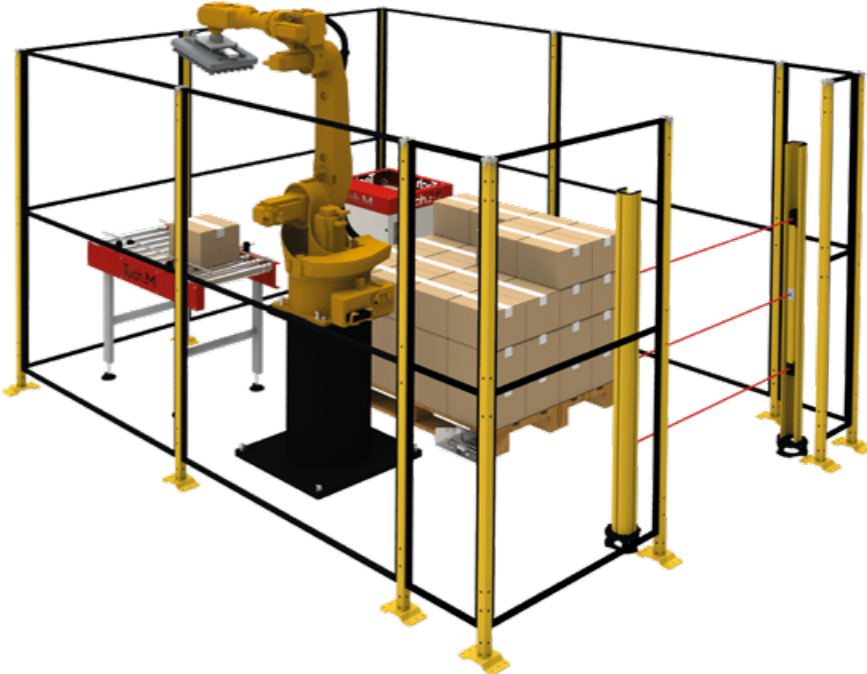

**M\_PAL**  
Compact  
palletizing cell



# CE15

Tech\_M

MANUAL LOADING AND UNLOADING STATION

## M\_PAL Compact palletizing cell

Optimize the palletizing of your boxes with this highly efficient cell that integrates easily into any space on your production line.

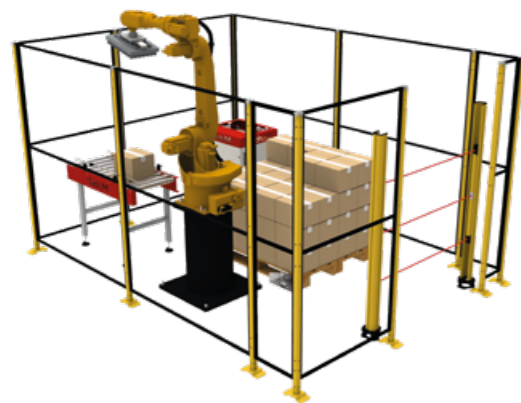

### PRODUCT

Type	Boxes
Dimensions	400x300x300 mm
Max. weight	17 kg

### PRODUCTION

8 cycles/min
--------------

### PALET

Max. dimensions	1200x1000 mm
Height	1700 mm (opc. 2400 mm)

### COMPONENTS

- 1 Motorized roller conveyor — box infeed
- 2 ESTUN palletizing robot, model ER20B-1760
- 3 Pallet positioning stop
- 4 Safety barrier
- 5 Protective fencing assembly
- 6 Control panel

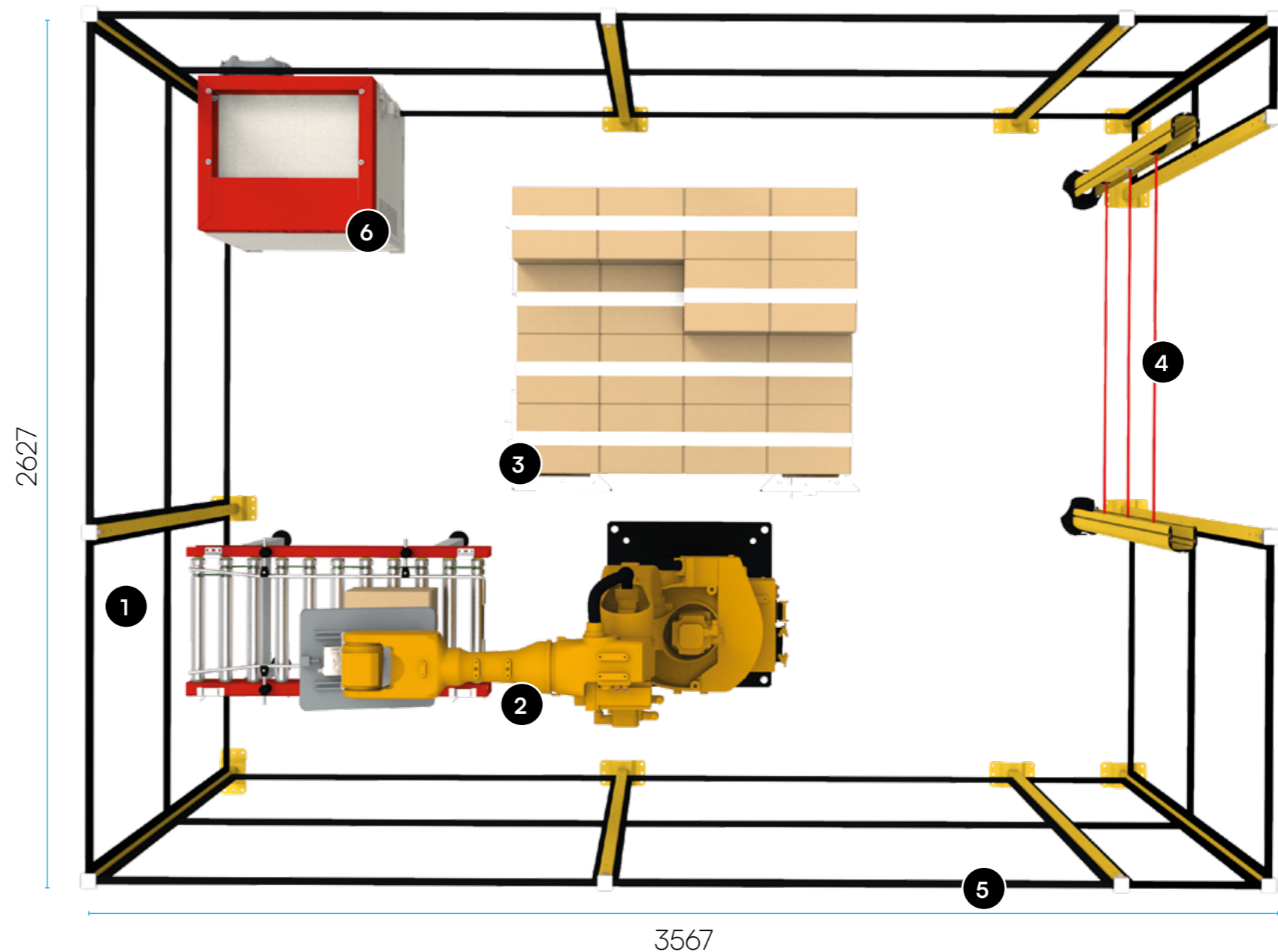

### Other configurations available

2 STATIONS WITH MANUAL  
LOADING AND UNLOADING

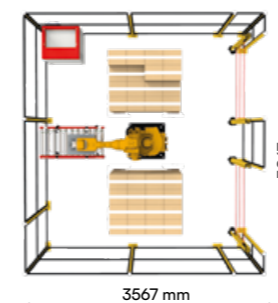

MOTORIZED PALLET  
CONVEYOR

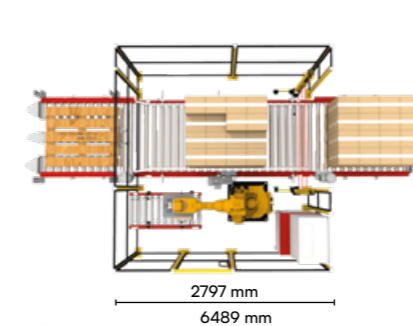

PALLET DISPENSER WITH  
MOTORIZED CONVEYOR

